

## **General E-S-QUAL Scales Applied To Websites Satisfaction and Loyalty Model**

**Hao-erl Yang**

Department of Business Management,  
Tatung University, Taipei, Taiwan  
[heyang@ttu.edu.tw](mailto:heyang@ttu.edu.tw)

**Feng-Shii Tsai**

Product Development Division  
Giantec Inc., Taipei, Taiwan  
[ferris@mail.giantec.com.tw](mailto:ferris@mail.giantec.com.tw)

### **ABSTRACT**

This study considers E-S-QUAL and E-RecS-QUAL, the newly developed multiple-item scales for assessing electronic service quality (e-SQ) in E-commerce, as the antecedents to Website satisfaction and assesses their effects on online consumer satisfaction and loyalty. Using online survey data from those who had nonroutine encounters with Websites, this study examines and validates the effectiveness of the e-SQ in explaining the variance in the e-shoppers' satisfaction and loyalty. The study results show that both E-S-QUAL and E-RecS-QUAL have strong and equal effects on satisfaction and loyalty, and all dimensions of these two constructs are important and influential factors to online satisfaction and loyalty. In addition, the mediating role of online satisfaction was assessed by using a structural equation modeling program when latent variables were included in the model. The findings constitute a contribution to, and extension of, the literature in the application of the e-SQ to Website service loyalty model and e-store management.

### **INTRODUCTION**

The role of service quality has been emphasized and comprehensively studied in services literature during the last 20 years (Fisk et al., 1993; Pitt et al., 1995; Parasuraman and Zeithaml, 2002). Traditionally, the SERVQUAL, a multiple item instrument, and its adaptations have been used to assess customer-perceived service quality, which has been validated as an important determinant in E-commerce channel satisfaction (Devaraj et al., 2002). With the increasing use of online shopping, the SERVQUAL instrument, recently, has been refined and validated to measure electronic service quality (e-SQ) delivered by Websites. However, few scholarly articles address directly with how customers assess e-SQ and its consequence (Parasuraman et al., 2005). Using conventional guidelines for scale development, Parasuraman et al. (2005) developed and validated a multiple-item scale for measuring e-SQ in online shopping contexts. Two different scales were derived for capturing e-SQ. The basic E-S-QUAL scale consists of 22 items on four dimensions: efficiency, fulfillment, system availability, and privacy, are used to assess the ease and speed of using Website, the implementation of the site's promises, the correct technical functioning of the site, and the safety of the site and the protection of customer information, respectively. The second scale, E-RecS-QUAL, containing 11 items in three dimensions: responsiveness, compensation, and contact, are employed when customer had nonroutine encounters to measure the effectiveness of handling problems and return, compensation for problems, and availability of assistance, respectively. Without any question the Internet is becoming an important and powerful way to distribute goods and services over the last decade. There are increasing number of firms using the Internet as the new distribution channel, and many with great success. In addition to system quality and information quality, service quality has been considered and evidenced as an important factor in measuring information systems (IS) success and a pivotal antecedent to customer satisfaction in online shopping environment (Pitt et al., 1995; Rodgers et al., 2005).

The importance of loyalty has been emphasized recently because loyal customers may be worth up to ten times as much as its average customer and bring many benefits to a seller and be considered one of the critical indicators used to measure the success of marketing strategy (Anderson & Srinivasan, 2003; Yoon & Uysal, 2005). Most companies try their best to continually satisfy their customers and develop long-run relationships with them. Without customer loyalty, even the best-designed e-business model will soon fall apart. Meanwhile, customer satisfaction seems to be an important barometer of customer's behavioral intentions and has been regarded as an important antecedent of loyalty (Anderson & Srinivasan, 2003; Yang & Yeh, 2006). In recent marketing research, the measures of perceived quality, satisfaction, and loyalty on behalf of customers have been used to assess firm's productivity and its marketing performance (Cortinas et al., 2004). Although the relationship between satisfaction and loyalty seems almost intuitive, the relationship has been found vary significantly under different conditions (Anderson & Srinivasan, 2003). Online service quality may impact e-tail success through online customer satisfaction and loyalty (Weathers and Makienko, 2006). Consumer satisfaction has been the subject of much attention in the literature because of its potential influence on consumer behavioral intention and customer retention (Cronin, Jr. et al., 2000). Similarly, in a B2C channel satisfaction model, satisfaction is considered as an important construct because it affects participants' motivation to stay with the channel (Devaraj et al., 2002). An understanding the role, specifically, the mediating role of the satisfaction in the model including perceived quality, satisfaction, and loyalty must be a basic parameter used to evaluate the performance of products and services (Yoon and Uysal, 2005). Few studies have investigated these issues in an online shopping service context, so this study employs the extended model as a conceptual framework to examine the effects of e-SQ on Website consumer satisfaction and loyalty and explain consumers' behavioral intentions (Anderson & Srinivasan, 2003). The purposes of this paper are:

1. Based on the general online satisfaction and loyalty model to hypothesize a model by using Parasuraman et al.'s E-S-QUAL and E-RecS-QUAL scales as the constructs of e-SQ and test the model with empirical data.
2. To investigate the relative importance of the dimensions contained in E-S-QUAL and E-RecS-QUAL scales affecting e-shopping satisfaction and loyalty.
3. To assess the mediating effects of customer satisfaction in the online loyalty model including latent constructs.

The study considers E-S-QUAL and E-RecS-QUAL, the newly developed multiple-item scales, as the antecedents to Website satisfaction and assesses their effects on online consumer satisfaction and loyalty. Using online survey data from online shoppers who had nonroutine encounters with the Websites, the study examined and validated the effectiveness of the e-SQ in explaining the variance in the e-shoppers' satisfaction and loyalty. The findings constitute a contribution to, and extension of, the literature in the application of the e-SQ to Website service satisfaction model and e-store management.

## **METHOD AND RESULTS**

### **Conceptual Framework And Research Hypotheses**

The conceptual framework linking e-SQ, customer satisfaction, and loyalty is presented in Figure 1, where we treat E-S-QUAL construct of the e-SQ as a second-order latent construct as suggested by Parasuraman et al. (2005) and add E-RecS-QUAL construct in the model. It is intended to explain the two antecedents that affect Websites satisfaction and the consequences of customer satisfaction. The dimensions from E-S-QUAL and E-RecS-QUAL are used as the lens to examine online consumer satisfaction and loyalty. Recent research revealed that the measures of perceived quality, satisfaction, and loyalty on behalf of customers have been used to assess firm's productivity and its marketing performance (Cortinas et al., 2004). An understanding of customer satisfaction must be a basic parameter used to evaluate the performance of products and services (Yoon & Uysal, 2005). Consumer satisfaction has been the subject of much attention in the literature because of its potential influence on consumer behavioral intention and customer retention (Cronin, Jr. et al., 2000). Similarly, in a B2C channel satisfaction model, satisfaction is considered as an important construct because it affects participants' motivation to stay with the channel (Devaraj et al., 2002). The extant literature suggests that service quality is strongly related to online satisfaction (Carr, 2002; Devaraj et al., 2002).

Figure 1: Conceptual framework.

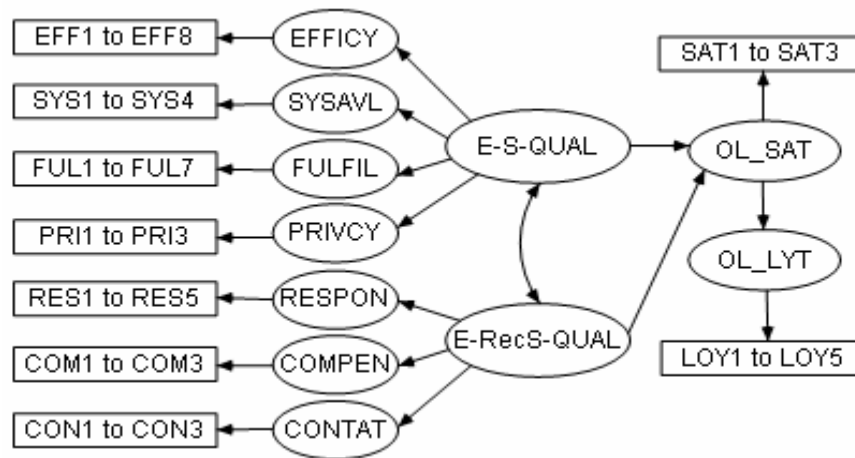

Prior research has found that satisfaction with a product or service has been identified as an important determinant for enhancing existing customers' loyalty. Satisfied customers are more likely to possess a stronger repurchase intention and to recommend the product/service to their acquaintances (Anderson, et al., 1994; Taylor & Baker, 1994; Reichheld & Teal, 1996; Skogland & Siguaw, 2004). Numerous studies have revealed that online customer loyalty resulted from customer's satisfaction with the EC channel and that the positive impact of online satisfaction on loyalty was evidenced in the context of electronic commerce (Hoffman et al., 1999; Devaraj et al., 2002; Yoon, 2002; Anderson & Srinivasan, 2003; Rodgers et al., 2005). From the review of the past research, it is presumable that high satisfaction with the online shopping will yield high online purchase intentions and loyalty.

Previous studies consider overall satisfaction to be primarily a function of perceived service quality (Cronin & Taylor, 1992; Parasuraman et al., 1988). Overall satisfaction reflects customer's cumulative impression of a firm's service performance and that, in turn, may serve as a better predictor of customer loyalty (Yang & Peterson, 2004). Recently, it has attracted researchers to pay attention to the formal tests of the mediation effects of customer satisfaction in an integrated loyalty model or behavioral intentions model (e.g., Gelade & Young, 2005; Yang & Lin, 2006). Therefore the mediating effects of online satisfaction when the mediational model involves latent constructs will be tested formally in this study.

Based on the foregoing review of the relationships between the e-SQ and its consequences suggests that the following hypotheses may be posited:

- H1:** Online satisfaction (OL\_SAT) will have a significantly positive impact on online loyalty (OL\_LYT).
- H2a:** Online satisfaction will be positively affected by E-S-QUAL.
- H2b:** Online satisfaction will be positively affected by E-RecS-QUAL.
- H3a:** Online satisfaction (OL\_SAT) will mediate the effects of E-S-QUAL on the online loyalty (OL\_LYT).
- H3b:** Online satisfaction (OL\_SAT) will mediate the effects of E-RecS-QUAL on the online loyalty (OL\_LYT).

## SAMPLE AND MEASUREMENT

The data was collected by online survey from 278 participants with usable questionnaires. The participants included 75.2% females, of which 94.6% in the range of 21 to 50 years old, 82.4% having at least college degree, and all participants had nonroutine encounters with the sites.

To examine the associations among the constructs and to test the hypotheses mentioned above, an online survey questionnaire was established on a survey portal provided by Chunghwa Telecom, where the interested online users can connect the portal and complete the survey. SPSS 14.0 and AMOS 6.0 procedures were used to analyze the data.

Since outliers often have dramatic effects on the fitted model, the researchers identified outlying observations first. In order to test the hypotheses, this study relied on three sets of constructs and their indicators. All indicators came from the items in a survey questionnaire designed with a 7-point scale from strongly disagree (1) to strongly agree (7). The items, given in Appendix, that were validated in prior studies were used with minor wording modification to apply to an online shopping context (e.g., Devaraj et al., 2002; Park & Kim, 2003; Parasuraman et al., 2005).

E-S-QUAL was conceptualized as a second-order model of four constructs, which were assessed by four dimensions: efficiency (measured by eight items, EFF1 ~ EFF8, Cronbach's alpha  $\alpha=0.925$ ), fulfillment (seven items, FUL1 ~ FUL7,  $\alpha=0.941$ ), system availability (four items, SYS1 ~ SYS4,  $\alpha=0.868$ ), and privacy (three items, PRI1 ~ PRI3,  $\alpha=0.916$ ). Similarly E-RecS-QUAL was assessed by 11 items in three dimensions: responsiveness (five items, RES1 ~ RES5,  $\alpha=0.921$ ), compensation (three items, COM1 ~ COM3,  $\alpha=0.805$ ), and contact (three items, CON1 ~ CON3,  $\alpha=0.900$ ). Online satisfaction (OL\_SAT) was measured by three items (SAT1 ~ SAT3,  $\alpha=0.926$ ) and online loyalty (OL\_LYT) by five items (LOY1 ~ LOY5,  $\alpha=0.947$ ). The reliability of measures (Cronbach's alpha) for the constructs ranged from 0.805 (compensation) to 0.947 (B2CLTY), exceeding the generally accepted level of 0.7 (Nunnally & Bernstein, 1994) and demonstrating high internal consistency and hence reliability of each dimension.

After examining the data, no severe cases were identified as outliers from multivariate perspective with the Mahalanobis  $D^2$  measure (all ratios of  $D^2/df \leq 4.0$ ) (Hair et al., 2006). The maximum likelihood method used in this study can be deployed for the data with minor deviations from normality (Wisner, 2003), even when the data deviate moderately from a normal distribution (Chou & Bentler, 1995). Consequently, a simple check of normality, i.e., a P-P plot for each variable used in the model, was conducted and the data appeared to be approximately normally distributed. Besides, the univariate skewness and kurtosis for all items in the sample were checked and they were ranging from  $-0.180$  (COM2) to  $-1.492$  (COM2) for skewness and  $-0.759$  (COM2) to  $3.180$  (SAT1) for kurtosis, within the maximum limits of an absolute value of two for skewness and seven for kurtosis recommended by West et al. (1995). We also checked the multicollinearity when a total of 41 indicators for nine constructs in the questionnaire were analyzed together in the model. The results indicated that the variance of inflation factors (VIFs) ranging from 1.99 (COM3) to 8.16 (FUL2), which did not exceed the recommended threshold of 10 (Kline, 2005; Kutner et al., 2005) and all variables were kept in the proposed model for further analysis.

Although the items used as the indicators to measure the constructs in this study were based on related literature review, tests of convergent validity, discriminant validity, and reliability were important for establishing construct validity (Ahire et al., 1996; Tu et al., 2001). Anderson and Gerbing's (1988) recommendations were followed first in evaluating and refining the measurement model prior to the simultaneous estimation of the measurement and structural models. Then, confirmatory factor analysis (CFA) was used to check construct validity of the measurement model, combining the nine constructs with more precise test (Byrne, 1998).

A confirmatory factor analysis (CFA) was conducted to assess the measurement model, including nine constructs with multiple indicators and refined according to the modification indices allowing some pairs of error terms to have non-zero covariance. Since the generally used goodness-of-fit indices such as  $\chi^2$ , Goodness-of-Fit Index (GFI) and Adjusted Goodness-of-Fit Index (AGFI) are considerably influenced by variations in sample size and nonnormality of the variables, current researchers recommend that a model reporting the relative chi-square  $\chi^2/df$  and the more robust measures such as Comparative Fit Index (CFI), Tucker-Lewis Index (TLI), and the Root Mean Square Error of Approximation (RMSEA) will often provide sufficient unique information to evaluate a model (Varki and Colgate, 2001; Hair et al., 2006). The measurement model fit showed that the ratio  $\chi^2/df=2.341$  ( $<5$ ), CFI=0.91, TFI=0.90, IFI=0.91 ( $>0.9$ ), and RMSEA=0.07 ( $<0.07$ ), met the generally recommended threshold levels. The results revealed that all standardized factor loadings were statistically significant at  $p<0.000$  and each individual item's coefficient was greater than twice its standard error, reflecting that the items represent their corresponding underlying construct (see appendix). The composite reliability values, weighted by factor loadings, ranging from 0.83 (COMPEN) to 0.95 (OL\_LYT), exceeded the often used practical level of 0.70, indicating an acceptable internal consistency for each construct (Nunnally & Bernstein, 1994; Hair et al., 2006). The average variance-extracted estimates (AVE), ranging from 0.61 (EFFICY) to 0.81 (OL\_SAT), exceeded the 0.50 lower limit (Fornell & Larcker, 1981; Hair et al., 2006). All the three evidences supported the convergent validity of the items as measures of their respective underlying constructs.

To test discriminant validity, each possible pair of constructs by constraining the estimated correlation parameter between them to 1.0 was assessed. All the differences in  $\chi^2$  values for the fixed and free solutions were significant at  $p < 0.000$  indicating the existence of discriminant validity of any two constructs. However, this is a necessary condition; a complementary method was also used to assess the discriminant validity. In the measurement model, the confidence interval ( $\pm$  two standard errors) around the correlation estimate between any two constructs did not include 1.0; the discriminant validity is evidenced (Anderson & Gerbing, 1988). The results of the CFA model suggest a high statistical measurement quality associated with the nine constructs.

One-factor confirmatory factor analysis was used to test the potential common method variance in survey research (Devaraj et al., 2002; Boyer & Hult., 2005). The results of one-factor model yielded a  $\chi^2 = 5423.63$  and  $df = 780$  compared with the  $\chi^2 = 1706.93$  and  $df = 729$  for the measurement model. The significant difference  $\Delta\chi^2 = 3716.7$  with  $df = 51$  ( $p < 0.000$ ) indicates that the fit is considerably worse for one-factor model than for the measurement model suggesting that common method variance is not a threat to the analysis and interpretation of the data.

**RESULTS**

**Hypotheses Testing**

A structural equation modeling (SEM) using AMOS 6.0 tested the model presented in Figure 1. The estimated model includes two second-order exogenous measurement models and two endogenous measurement models and paths among latent constructs. The proposed model fit showed that all goodness-of-fit indices such as, the ratio  $\chi^2/df = 2.394$ , CFI=0.91, TFI=0.90, and RMSEA=0.07, met the generally recommended threshold levels suggested that the proposal model fitted the data well and the hypothesized relationships were tested. The results revealed that all standardized factor loadings were statistically significant at  $p < 0.000$ .

Table 1 shows the estimated path coefficients of the model and the squared multiple coefficients (SMC) for dependent latent constructs, which provide an estimate of variance explained. Hypothesis H1 predicts positive impact from online satisfaction on online loyalty is significantly supported with estimated standardized path coefficients 0.882 ( $p < 0.000$ , SMC=0.782). Hypotheses H2a and H2b predicted a positive influence of E-S-QUAL and E-RecS-QUAL, respectively, on OL\_SAT. The results show that the standardized path coefficients were 0.435 ( $p < 0.01$ ) and 0.412 ( $p < 0.01$ ), respectively. The squared multiple coefficient for online satisfaction is 0.646 ( $p < 0.001$ ) meaning a large portion of the variation in online satisfaction is accounted for by E-S-QUAL and E-RecS-QUAL. Therefore, hypotheses H1, H2a, and H2b are supported.

**Table 1: Hypotheses results for the structural model.**

	Research hypothesis	R <sup>2</sup>	Beta coefficients	Standard Error	t-value*	Conclusion
H1	OL_SAT → OL_LYT	0.782	0.882	0.025	35.280	Supported
H2a	E-S-QUAL → OL_SAT	0.646	0.435	0.136	3.199	Supported
H2b	E-RecS-QUAL → OL_SAT		0.412	0.141	2.922	Supported

\* All t-values are significant at  $p < 0.01$ .

**Mediating Effects**

In this study we suggested that OL\_SAT will mediate the effects of E-S-QUAL and E-RecS-QUAL on OL\_LYT, respectively. The mediation analysis would be done by a structural equation modeling program when latent variables were included in the model (Kenny, 2006), and the measures and tests of indirect effect can address mediation more directly than a series of separate significance tests not directly involving the indirect effect in the mediation model (Preacher and Hayes, 2004). The amount of mediation of one initial variable (e.g., E-S-QUAL, an

antecedent of the mediator OL\_SAT) can be estimated by the indirect effect of the initial variable when adding the path from the initial variable to the so-called outcome variable (i.e., OL\_LYT), while controlling the mediator and the other initial variable (i.e., E-RecS-QUAL) as covariate in the mediation model (Kenny, 2006). In the mediation model the total effect can be used to estimate the direct effect of the initial variable on the outcome variable when the model does not include the mediator. If the total effect of the initial variable is significant meaning that there is an effect that can be mediated. In addition, if the direct effect is not significant, the mediator has a complete mediating effect on the relationship between the initial variable and the outcome variable. If the direct effect is significant, the mediator has a partial mediating effect on the relationship between the initial variable and the outcome variable.

Using AMOS 6.0 with 3000 bootstrapping samples to assess the total, direct, and indirect effects with standard errors as given in Table 2, the results showed that the indirect effect of E-S-QUAL and E-RecS-QUAL on OL\_LYT were 0.332 (t=2.887, p<0.01) and 0.282 (t=2.474, p<0.05), respectively. Meanwhile, their direct effects on OL\_LYT were not significant at p<0.05, demonstrating that OL\_SAT strongly mediated the effect of E-S-QUAL and E-RecS-QUAL on OL\_LYT, respectively. The H3a and H3b were supported, that is, online satisfaction completely mediated the effects of E-S-QUAL and E-RecS-QUAL on OL\_LYT.

**Table 2: The direct, indirect, and total effects.**

Paths		Direct Effect	Indirect Effect	Total Effect
OL_SAT	→ OL_LYT	0.739		0.739
		<b>7.465</b>		<b>7.465</b>
E-S-QUAL	→ OL_SAT	0.45		0.45
		<b>3.191</b>		<b>3.191</b>
	→ OL_LYT	0.005	0.332	0.338
		<b>0.041</b>	<b>2.887</b>	
E-RecS-QUAL	→ OL_SAT	0.382		0.382
		<b>2.616</b>		2.616
	→ OL_LYT	0.178	0.282	0.46
		<b>1.854</b>	<b>2.474</b>	<b>3.007</b>

NOTE: Based on two-tailed tests, t values, *in bold italic font style*, greater than 1.96 are significant at p<0.05; t values greater than 2.58 are significant at p<0.01.

**Relative Importance of the e-SQ Dimensions**

For comparison with the results reported by Parasuraman et al.(2005), an exploratory factor analysis of the ratings on the 33 items (22 items for E-S-QUAL scale and 11 items for E-RecS-QUAL scale) with the use of principal components analysis and varimax rotation was conducted and seven relatively clean orthogonal factors, all items, with three exceptions, loaded very strongly on their a prior dimensions, were extracted with 77.15% of the variance in the items accounted for by the seven factors. Using the seven factors as independent variables and one satisfaction factor (accounted for 87.42% of the variance in three items) and one loyalty factor (accounted for 83.02% of the variance in five items) as dependent variables, the results of the two regression analyses were given in Table 3. The results demonstrated that the pattern of effects is consistent across dependent variables and suggests that the factors representing efficiency, fulfillment, and responsiveness have the strongest effects, followed by contact and then privacy and compensation. Since the seven factors are orthogonal, the relative importance of the

four E-S-QUAL dimensions can be obtained directly from Table 3 and the pattern of effects is consistent with that reported by Parasuraman et al. (2005).

**Table 3: Regression analysis of satisfaction and loyalty on e-SQ dimensions.**

Independent Variables	Satisfaction		Loyalty	
	Beta	t values	Beta	t values
Efficiency	0.327	8.282	0.331	7.989
System availability	0.217	5.495	0.135	3.264
Fulfillment	0.393	9.960	0.419	10.113
Privacy	0.185	4.693	0.177	4.278
Responsiveness	0.372	9.422	0.320	7.727
Compensation	0.122	3.092	0.162	3.902
Contact	0.291	7.376	0.272	6.569
Adjusted R <sup>2</sup>	<b>0.580</b>		<b>0.525</b>	

NOTE: All t-values are significant at  $p < 0.01$ .

## CONCLUSION

The generic and parsimonious E-S-QUAL and E-RecS-QUAL scales were tested reliable and valid and can be used in an online loyalty model. Tests of the effects of the two second-order constructs on online satisfaction and loyalty indicate that both E-S-QUAL and E-RecS-QUAL have strong and significant effects on satisfaction and that, in turn, significantly affect customer loyalty. Moreover, when checking the loadings of the dimensions on their corresponding constructs, we find that all loadings are significant and above 0.75, indicating that all dimensions of the two constructs are important factors to influence online satisfaction and loyalty. However they are important in a very unique way. Overall the most important dimension is fulfillment in influencing satisfaction and loyalty, followed by efficiency and responsiveness and then contact. Although system availability and compensation are less critical of the seven e-SQ dimensions, the regression results showed that both dimensions still have statistically significant impacts on customers' satisfaction and loyalty to Websites.

This study contributes and extends a growing research stream documenting the mediating role of online satisfaction in an integrated online loyalty model. Consumer behavior researchers have documented the vital role of customer satisfaction in a variety of customer behavior model but rarely researched, especially in an online shopping environment, with mediating effects. With empirical data and formally statistical test, we found that online satisfaction significantly mediates the effects of service quality on online satisfaction, and that in turn, to be an important factor determining online shopping loyalty. The findings constitute a contribution to, and extension of, the literature in online shopping and e-store management.

Although the findings provide meaningful implications for e-stores, there are some limitations of this study which should be addressed in the future. First, there are other important antecedents of online satisfaction, such as information quality and system quality, in addition to service quality, being considered in an online satisfaction and loyalty model (Rodgers, et al., 2005), not included in the study. Second, value, trust, commitment, relational benefit, and others have been considered as important mediators in online shopping and online-purchase decisions model but not included in this study (Yoon, 2002; Park & Kim, 2003). Further studies may consider an integrated online loyalty model with multiple antecedents of online satisfaction and multiple mediators, and formally test the mediating effects of the mediators to understand consumers' online shopping behavior and the differential effects of these antecedents and mediators.

## REFERENCES

- Ahire, S. L., Golhar, D. Y. & Walter, M. A. (1996). Development and Validation of TQM, *Implementation Constructs. Decision Science*, 27(1), 21-56.
- Anderson, E. W., Fornell, C. & Lehman, D. (1994). Customer Satisfaction, Market Share, and Profitability: Findings from Sweden, *Journal of Marketing*, 58, 53-66.
- Anderson, J. C. & Gerbing, D. W. (1988). Structural Equation Modeling in Practice: A Review and Recommended Two-step Approach, *Psychological Bulletin*, 103(3), 411-423.
- Anderson, R. E. & Srinivasan, S. S. (2003). E-satisfaction and E-loyalty: A Contingent Framework, *Psychology & Marketing*, 20(2), 123-138.
- Boyer, K. K. & Hult, G. T. M. (2005). Extending the Supply Chain: Integrating Operations and Marketing in the Online Grocery Industry, *Journal of Operations Management*, 23, 642- 661.
- Byrne, B. M. (1998). *Structural Equation Modeling with LISREL, PRELIS, and SIMPLIS: Basic Concepts, Applications, and Programming*. NJ: Lawrence Erlbaum Associates, Inc.
- Carr, C. L. (2002). A Psychometric Evaluation of the Expectation, Perception, and Difference-scores Generated by the IS-adapted SERVQUAL Instrument, *Decision Science*, 33, 281-296.
- Chou, C. P. & Bentler, P. M.(1995). Estimates and Tests in Structural Equation Modeling, In: Hoyle, R. H. (Editors): *Structural Equation Modeling*. Thousand Oaks, CA: Sage Publications, 37-55.
- Cortinas, M., Elorz, M. & Villanueva, M. L.(2004). Retail Store Loyalty Management Via an Analysis of Heterogeneity of the Service Elements. *Int. Rev. of Retail, Detail, Distribution, and consumer Research*, 14(4), 407-436.
- Cronin, Jr., J. J. & Taylor, S. A. (1992). Measuring Service Quality: A Reexamination and Extension, *Journal of Marketing*, 56, 55-68.
- Cronin, Jr., J. J., Brady, M. K., & Hult, G. T. (2000). Assessing the Effects of Quality, Value, and Customer Satisfaction on Consumer Behavioral Intentions in Service Environments. *Journal of Retailing*, 76(2) 193-218.
- Devaraj, F., Fan, M. & Kohli, R. (2002). Antecedents of B2C Channel Satisfaction and Preference: Validating E-commerce Metrics, *Information System Research*, 13(3), 316-333.
- Fisk, R. P., Brown, S. W., & Bitner, M. J. (1993). Tracking the Evolution of the Services Marketing Literature. *Journal of Retail*, 69(1), 61-103.
- Fornell, C. & Larcker, D. F. (1981). Evaluating Structural Equations Models with Unobservable Variables and Measurement Error, *Journal of Marketing Research*, 18, 39-50.
- Gelade, G. A. & Young, S. (2005). Test of a Service Profit Chain Model in the Retail Banking Sector, *Journal of occupational and organizational Psychology*, 16, 1-22.
- Hair Jr., J. F., Black, W. C., Babin, B. J., Anderson, R. E. & Tatham, R. L. (2006). *Multivariate Data Analysis 6th ed.* Upper Saddle River, NJ: Prentice-Hall.
- Hoffman, D. L., Novak, T. P. & M. A. (1999). Peralta, Information privacy in the Market Space: Implications for the Commercial Uses of Anonymity on the Web, *Inform. Soc.* 15(2), 129-139.

- Kenny, D. A. (2006, February 7). Mediation. Available at: <http://davidakenny.net/cm/mediate.htm>.
- Kline, R. B. (2005). *Principles and Practice of Structural Equation Modeling*, 2<sup>nd</sup> ed. New York: The Guilford Press.
- Kutner, M. H., Nachtsheim, C. J., Neter, J., & Li, W. (2005). *Applied Statistical Models* 5<sup>th</sup> ed. New York: McGraw-Hill.
- Nunnally, J. C. & Bernstein, I. H. (1994). *Psychometric Theory* 3<sup>rd</sup> ed. New York: McGraw-Hill.
- Parasuraman, A. & Zeithaml, V. A. (2002). Measuring and Improving Service Quality: a Literature Review and Research Agenda, In *Handbook of marketing*, Bart Weitz, ed., Thousand Oaks, CA: Sage.
- Parasuraman, A., Zeithaml, V. A. & Malhotra, A. (2005). E-S-QUAL: A Multiple-item Scale for Assessing Electronic Service Quality, *Journal of Service Research*, 7 (3), 213-233.
- Parasuraman, A., Zeithaml, V. L. & Berry, L. L (1988). SERVQUAL: A Multiple-item Scale for Measuring Consumer Perceptions of Service Quality, *Journal of Retailing*, 64(1), 12-40.
- Park, Chung-Hoon & Kim, Young-Gul (2003). Identifying key Factors Affecting Consumer Purchase Behavior in an Online Shopping Context, *International Journal of Retail & Distribution Management*, 31(1), 16-29.
- Preacher, K. J.; Hayes, A. F. (2004). SPSS and SAS Procedures for Estimating Indirect Effects in Simple Mediation Models, *Behavior Research Methods, Instruments, & Computers*. 36, 4, 717-731
- Pitt, L. F., Watson, R. T. & Kavan, C. B. (1995). Service Euality: A Measure of Information Systems Effectiveness, *MIS Quarterly*, 19, 173-187.
- Reichheld, F. F. & Teal, T. (1996). *The Loyalty Effect*. Boston, MA: Harvard Business School press.
- Rodgers, W., Negash, S. & Suk, K. (2005). The Moderating Effect of On-line Experience on the Antecedents and Consequences of On-line Satisfaction, *Psychology & Marketing*, 22(4), 313-331.
- Skogland, I. & Siguaw, J. A. (2004). Are Your Satisfied Customers Loyal? *Cornell Hotel and Restaurant Administration Quarterly*, 46(3), 221-234.
- Taylor, S. A. & Baker, T. I. (1994). An Assessment of the Relationship between Service Quality and Customer Satisfaction in the Formation of Customers Purchase Intentions, *Journal of Retailing*, 70(2), 163-178.
- Varki, S. and Colgate M. (2001). The Role of Price Perceptions in an Integrated Model of behavioral Intentions, *Journal of Service Research*, 3 (3), 232-240.
- Tu, Q., Vonderembse, M. A. & Ragu-Nathan, T. S. (2001). The Impact of Time-based Manufacturing Practices on Mass Customization and Value to Customer, *Journal of Operations Management*, 19, 201-217.
- Weathers, Danny and Makienko, Igor (2006). Assessing the Relationships between E-tail Success and Product and Web Site Factors, *Journal of interactivity marketing*, 20(2), 41-54.
- West, S. G., Finch, J. F. & Curran, P. J. (1995). Structural Equation Models with Nonnormal Variables: Problems and Remedies, In: Hoyle, R. H. (Editors). *Structural Equation Modeling*. Thousand Oaks, CA: Sage Publications, 56-75.
- Wisner, J. D.(2003). A Structural Equation Model of Supply Chain Management Strategies and Firm Performance, *Journal of Business Logistics*, 24(1), 1-25.

Yang, Hao-erl and Yeh, Kun-huang (2006). The Roles of Service Quality and Mediating Factors in a Customer Behavioral Intentions Model, *Int. J. Services Operations and Informatics*, 1(1/2), pp. 38-53, 2006.

Yang, Hao-erl & Lin, Shih-hsuan (2006). The Role of Customer Satisfaction in an Online Shopping Environment. Available at: [http://www.iamot.org/conference/papers.php?first\\_letter=all&cf=10](http://www.iamot.org/conference/papers.php?first_letter=all&cf=10).

Yang, Z. & Peterson, R. T. (2004). Customer Perceived Value, Satisfaction and Loyalty: The Role of Switching Costs. *Psychology & Marketing*, 21(10), 799-822.

Yoon, Sung-Joon (2002). The Antecedents and Consequents of Trust in Online-purchase Decisions, *Journal of Interactive Marketing*, 16(2), 47-63.

Yoon, Y. & Uysal, M. (2005). An Examination of the Effects of Motivation and Satisfaction on Destination Loyalty: a Structural Model. *Tourism Management*, 26, 45-56.

## APPENDIX

Measurement items for the nine constructs in the model

Constructs items	Factor Loadings	t-values (*)
<b>Efficiency (EFFICY)</b> ( $\alpha=0.925$ , AVE=0.608)(#)		
EFF1: Easy to find what I need.	0.680	14.47
EFF2: Easy to surf anywhere.	0.662	13.79
EFF3: Completes a transaction quickly.	0.711	18.71
EFF4: Well-organized information.	0.856	42.80
EFF5: Load pages fast.	0.814	29.07
EFF6: Easy to use.	0.847	38.50
EFF7: Enter the site quickly.	0.823	26.55
EFF8: Well-organized site.	0.818	34.08
<b>System Availability (SYS AVL)</b> ( $\alpha=0.863$ , AVE=0.613)		
SYS1: Available for business.	0.844	21.64
SYS2: Ready for use.	0.855	25.15
SYS3: Does not crash.	0.680	15.11
SYS4: Responds to the order information.	0.739	16.80
<b>Fulfillment (FULFIL)</b> ( $\alpha=0.937$ , AVE= 0.680)		
FUL1: Delivers orders when promised.	0.846	22.26
FUL2: Items available for delivery in time.	0.875	41.67
FUL3: Delivers the ordered items quickly.	0.857	35.71
FUL4: Sends out the items ordered.	0.793	22.66
FUL5: Has items in stock.	0.754	19.84
FUL6: It is truthful about its offerings.	0.783	16.66
FUL7: Accurate promises about product delivery.	0.856	34.24
<b>Privacy (PRIVCY)</b> ( $\alpha=0.918$ , AVE=0.788)		
PRI1: Protects my shopping behavior information.	0.893	33.07
PRI2: Protects my personal information.	0.891	40.50
PRI3: Protects my credit card information.	0.879	31.39
<b>Responsiveness (RESPON)</b> ( $\alpha=0.909$ , AVE=0.666)		
RES1: Return items conveniently.	0.759	18.51
RES2: Handles product returns well.	0.796	24.12
RES3: Offers a meaningful guarantee.	0.843	26.34
RES4: Instructs me to process my transaction.	0.785	21.22
RES5: Take care of problems quickly.	0.892	35.68
<b>Compensation (COMPEN)</b> ( $\alpha=0.831$ , AVE=0.631)		
COM1: Compensates me for site's problems.	0.941	44.81
COM2: Compensates me for not delivering items on time.	0.841	36.57
COM3: Picks up the product I want to return.	0.549	9.63
<b>Contact (CONTAT)</b> ( $\alpha=0.902$ , AVE= 0.755)		
CON1: Provides a line for contact.	0.810	24.55
CON2: Has service representatives online.	0.904	25.83
CON3: Has a live person online.	0.889	29.63

(continued)

## Measurement items for the nine constructs in the model (continued)

Constructs items	Factor Loadings	t-values (*)
<b>Online Satisfaction (OL_SAT) (alpha=0.928, AVE=0.811)</b>		
SAT1: Overall satisfaction level.	0.884	42.10
SAT2: Overall satisfaction level comparing with others.	0.914	33.85
SAT3: Overall quality comparing with others.	0.904	39.30
<b>Online Loyalty (OL_LYT) (alpha=0.945, AVE=0.774)</b>		
LOY1: Say positive things about this site.	0.898	47.26
LOY2: Recommend this site to someone.	0.921	65.79
LOY3: Encourage someone surfing on this site.	0.887	49.28
LOY4: My first choice for future transaction.	0.869	36.21
LOY5: Do more business with this site in the coming months.	0.822	28.34

#: alpha= composite reliability; AVE=average variance extracted of construct.

\*: all t values are significant at  $p < 0.000$ .