

# **The Micro-Multinational – A Model For Small International Business**

**William E. Gerbacia**

*Iona College, Hagan School of Business, 715 North Avenue, New Rochelle, NY, 10801*

**Bryan E. Gerbacia**

Chief Technical Officer, Ad-Station Systems, Inc., Box 232, Lincroft, NJ

## **ABSTRACT**

*With the recent advances in telecommunications networking and teleconferencing software, small companies can become more cost competitive by outsourcing appropriate functions to lower wage countries. Ad-Station Systems is a startup media advertising company that provides a number of online and off-line advertising services. The online product offering requires support and programming. It was decided to evaluate whether these functions could be provided from a foreign location. An industrial dynamics model indicated that this is a viable option. The processes were designed and documented, and are described here.*

## **INTRODUCTION**

Large and mid-sized companies have been establishing international operations for many decades. It is rare for small companies to do so, and rarer still when a small startup begins operations as an international company. However, the facilities are now available that allow even small companies to establish themselves as international businesses from conception. In particular, if the business plan requires a support function for which the information can be transformed into or is in electronic format, the small business planner should consider whether all or part of that function can be provided by an overseas operation. There has been some mention already that some venture capitalists are insisting that new ventures should begin outsourcing for services from inception (Gumpert, 2004).

It is imperative even for small companies to take advantage of the most cost efficient means of satisfying their requirements for the goods and services that they need. Costs include all costs, both direct and opportunity costs. No advantage is gained if in achieving lower direct costs for services, the company incurs the opportunity costs of lost customers because management cannot properly coordinate the provision of those services. However, careful consideration must be given to all possible providers since the competition will be seeking the advantage. So, it behooves small company managements to consider all possibilities for outsourcing services, and developing the expertise to manage them whenever possible

Ad-Station Systems, Inc. is a small startup company that, as one of its product offerings, provides internet advertising space to businesses. As such, the company requires the skills of several programmers, designers, and maintenance personnel. These personnel are required for application development, site maintenance, and the customer fulfillment function. Although two of the principals have extensive programming and design experience, their time is more required for planning, coordination, and marketing activities.

The new venture's management decided early in the development of its business plan to evaluate outsourcing some of its support programming and customer fulfillment needs to a foreign provider as a preliminary step to expanding its own capabilities in a foreign location. The support envisioned was to augment the resources available in its U.S. location. Since management has considerable international business experience, and is very comfortable in the international arena, this seemed a viable option.

Locating a provider of required services can be challenging even in one's home country. The risks and difficulties are compounded when a foreign provider is to be located. Considerable time is required. The management of Ad-Station Systems currently operates a small business in the Philippines. It was decided therefore to leverage this

advantage. The company's plan was to use a two stage process. Initially, services would be contracted - the international outsourcing phase. Subsequently, a support office would be established, completing the evolution to a micro-multinational corporation. The rationale for this plan is described in the Advantages to the Company's Approach section.

Discounting management's familiarity with the country, the Philippines offered a number of advantages which are discussed in the Country Selection section below. However, before investing in this approach, many factors needed to be considered, and several technical applications needed to be available to support the management of this process. The process that Ad-Station Systems used in developing its foreign sourced support function and its management can be used as a general template, and case study for any small business that is considering following an international outsourcing path, or establishing an office in a foreign location and thus become a micro-multinational company.

### ***The Outsourcing Imperative***

Over the last forty years of the previous millennium the United States has gone from a predominantly industrial based to a predominantly service based economy. The transition was accomplished by the wholesale international outsourcing of the bulk of its manufacturing capability. The increase in international outsourcing has not been limited to the United States. Hummels et al. (2001) provide evidence that a similar trend was apparent in the countries that are members of the Organization for Economic Cooperation and Development. Outsourcing grew 30% between 1970 and 1990. The global outsourcing market is expected to grow from the estimated \$3 billion in 2004 to \$24 billion in 2007 (Bhatnagar, 2005).

The gains realized by manufacturing companies through international outsourcing were not lost on the services industries. The current trend shows an increase in the international outsourcing of services (Amiti and Shang-Jin, 2005), typically by medium to large businesses. Support services are functions used extensively by small businesses. Now the technological solutions are in place at a price that can allow small companies to selectively take advantage of the international outsourcing option.

However, it must be realized that not all outsourcing activities have been reported to be successful (Ogasawara, 2004). For the outsourced software functions included in that survey results were surprisingly poor. More than half, 56%, of the work was reported to be of lower quality than in-house work. This includes 11% which was considered unusable. Most of these results were for activities that had been outsourced for two years or less. Although the survey was somewhat informal and possibly biased, the data highlights the fact that outsourcing may not be the lowest cost alternative when all costs are considered. Therefore, the decision to outsource should be made after sufficient evaluation has been conducted, as would be done for any major strategic decision.

Yet, the drivers for outsourcing can be compelling. In particular, productivity gains (Gorg, Hanley, Strobl, 2005) are expected to be derived from outsourcing activities if conducted properly. As these authors point out, in addition to the benefits flowing to the outsourcing economy, similar benefits should flow to individual plants in that economy. By analogy similar benefits should flow to the individual small business that can master the art of outsourcing. In the materials outsourcing arena skill levels as well as the skill premium of workers in the home country have been reported to climb. This rise results from an increased demand for skilled labor in the outsourcing country. There is some empirical evidence for this phenomenon (Feenstra and Hanson, 1999). So, over time the small business should be able to participate in this enhancement by gaining access to a larger pool of lower cost lower skilled workers outside and higher skilled workers inside its home country.

## **THE COMPANY'S PRODUCT AND PROCESS**

In order to understand Ad-Station's approach to international outsourcing, a brief description of the product and customer fulfillment process is provided.

### ***The Product***

Ad-Station System provides several on and off-line advertising products. However, at least initially, management wanted to focus on one product category for the initial international outsourcing exercise. Once foreign services were in place to provide support and customer fulfillment for this class of products, the service could be expanded to other classes.

The product selected was their online advertising function which provides an outlet for advertisers to place their existing advertising copy online at low cost. Ad-Station Systems reformats the copy to fit the new medium. Ads can have previously appeared in print, TV or radio. The ads are placed in a rotating panel on their site and Ad-Station then promotes the site to attract visitors. Ad-Station’s customers gain the advantage of additional exposure for their existing ad copy at a very low cost. A preliminary example of the site is shown in Figure 1.



Figure 1: Sample Web Site Product

Each advertiser can purchase space consisting of a 184x184 logo area from which an animation, video, or audio playback can be launched, or it can contain a static company image. The main ad space is a 508x180 banner and/or text space. The customer’s existing ad can be placed directly in this area, if fits this aspect ratio. Otherwise, the customer can have a banner ad displayed there, which when clicked, takes the user to a separate page on which the customer’s advertisement is displayed. The center area rotates the advertisements so that with each page view a different advertisement is on top. Ads on the side bars are fixed, and are charged at a higher rate.

In order to provide this service, the proper functionality needed to be built into the site, and additional functions needed to be provided in order to market and promote the site in order to attract viewers. In addition, once the site is functional the customer fulfillment process needs to be supported. Ad-Station planned to provide a substantial part of its support for these functions from a foreign location.



**The Customer Fulfillment Process**

The customer fulfillment process consists of administrative functions, such as receiving orders, data base entry, billing, etc., and technical functions, such as reformatting advertising content, installing advertising content on a web site, editing content, monitoring, etc. A high level flow diagram of the technical process is shown in Figure 2. The shaded functions are the ones that management proposed be serviced from the foreign location.

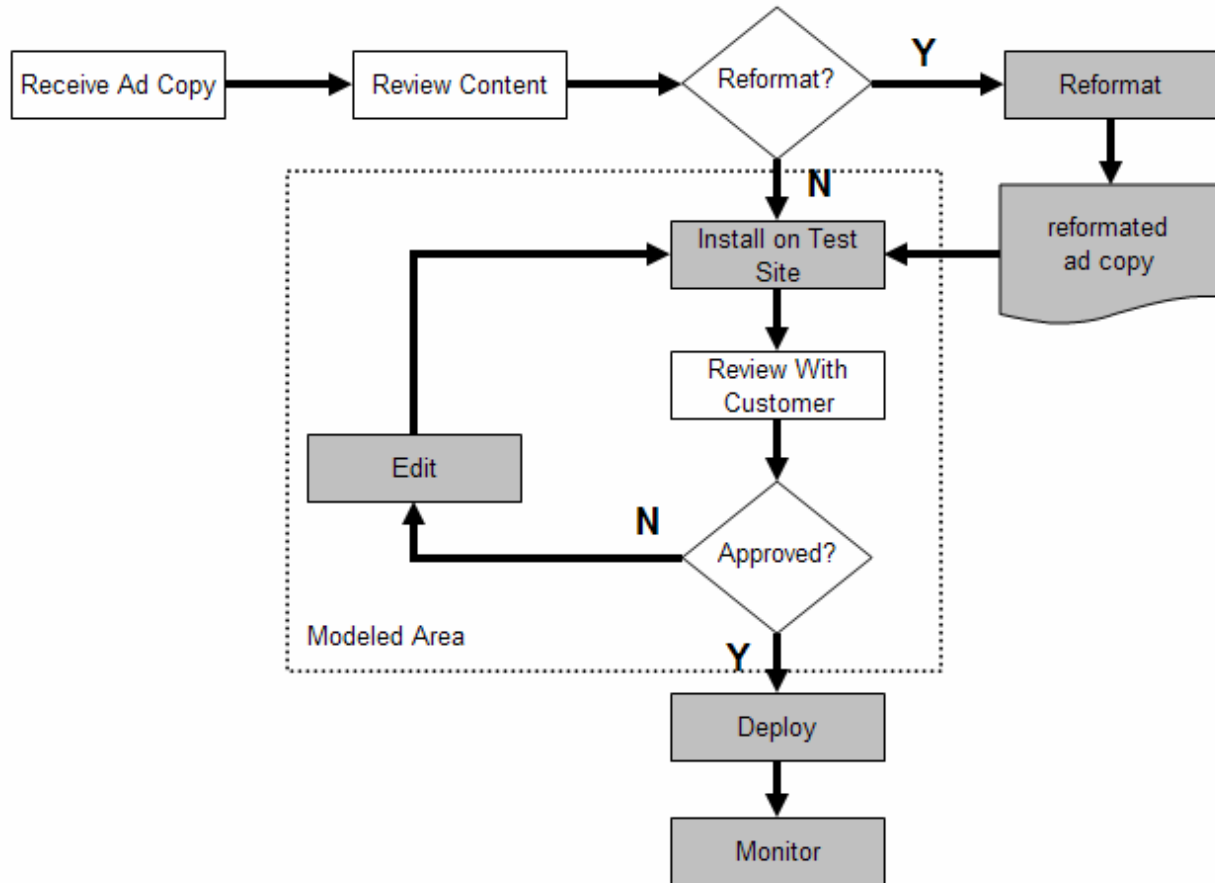

Figure 2 - Technical Portion of Customer Fulfillment Process

**REQUIREMENTS**

**Hardware**

In order to conduct the identified functions from a remote location, some means to efficiently transmit files, collaborate in real-time, and monitor activities at the foreign location is required. Sufficient computing power and communication bandwidth are also needed. The applications that are used to manipulate and edit the audio, video and graphics files require a fair amount of memory and CPU speed. The principles of Ad-Station Systems conducted many tests to determine the minimum system requirements. Similar system requirements are needed at both locations. In order to guarantee compatibility with the required software applications, components were tested in the United States. Once the system configuration was identified, the internal components were delivered to the foreign location for assembly on site.

## **Software**

It is absolutely essential to share files, and discuss issues in real-time. However, this is the minimum requirement. The complete set of requirements was the following:

- Real-time file sharing
- Real-time voice communication
- Share desk tops
- On screen drawing
- Low cost

Some organizations might want to add video conferencing to the list, but it was not deemed essential to the process, and would use up vital bandwidth. It is also apparent that the voice communication functionality can be satisfied using ordinary long distance telephone services. This functionality does not need to be built into the application.

There are a number of ways to satisfy these requirements. Not all of them meet the last requirement. There are two general classes of applications that provide this type of functionality: hosted services and licensed software. In the former, the application is running on a provider's server. The clients log in to their service and conduct their meeting. Using the latter option, a software license is purchased and the software is installed on an in-house computer which will act as a server for the process. This option provides more control over the meeting environment, but also requires a higher level of knowledge to implement. Also, one can be less concerned with the provider ceasing operations.

The principles at Ad-Station Systems evaluated a number of applications, such as MicroSoft Office Live Meeting™, GoToMeeting™, Linktivity™, e/POP™, WebEx™, Click To Meet™, iVisit™, and NetSupport™. Many of these applications have been evaluated by other authors (Woolley, 2006).

The most cost effective long term solutions were evaluated to be Linktivity™ and NetSupport™. Both of these are licensed software applications that can be installed on in-house servers. This aspect was given moderately high priority in the evaluation by the principles. Both applications also allow concurrent voice communication, but this was given low priority. However, NetSupport™ had also been evaluated previously by the company to monitor stand-alone computer installations for another product offering. Since this software could fill both rolls it was chosen for the conferencing application. Both are low cost which was given a high priority by company management, and puts them well within the budget of any small business.

## **COUNTRY SELECTION**

### ***Selection Factors***

Selection of the foreign location is extremely important. There are a number of factors that a micro or small company should consider when selecting a country to use as an outsourcing partner or in which to establish an affiliated support function.

Ad-Station's management considered the following ranked factors:

1. Significantly lower wage scale, and overhead costs
2. Little or no increase in opportunity costs
3. Minimize search costs
4. Sufficient number of candidates with the required technical skills who speak and write English
5. Availability of high speed communications infrastructure
6. Management familiarity with the culture and customs of the country
7. An established business support industry or an established company base from which to leverage
8. Sufficient protections for intellectual property rights
9. Time zone

### ***Costs***

The first two factors relate to costs. If there were no front end reduction in costs, there would be no apparent advantage to international outsourcing, or establishing an office. In the international outsourcing option, lower wage and overhead costs translate into lower costs for the services of a contractor compared to a similar function established in the home country. These costs include any additional implementation activities such as travel that might be incurred due to the international scope of the activity. Also, it must be understood that not all of the lower costs will be captured by the outsourcing company. Even though wage rates might be 80 to 90 percent lower in the foreign location, outsourcing companies generally only capture about 50% in reduced direct costs (Brainard and Litan, April 2004). Additional costs for managing the international connection will be incurred and must be accounted in the evaluation of the international outsourcing proposal.

The second factor relates to any opportunity costs that might be encountered. Costs in this category are generally hidden and often difficult to estimate even when they are identified. These include, for example, lost customers due to poor service or misunderstandings due to poor English comprehension on the part of the service provider. Consideration was given to this class of costs. The process described in Figure 2 is designed, partially, to address some of these issues. The foreign support providers are insulated from direct contact with the company's customers. In a situation in which this cannot be accomplished, for example a call center support function, management would need to monitor services closely and poll its customers frequently to certify that these opportunity costs were not escalating. These costs can easily overwhelm any savings on direct costs.

Search costs, the third factor, relate to finding a provider in a foreign location. If the company were to enter a country in which management had no experience or contacts, among others, travel, consulting, additional delay, and translation costs would be incurred. These can be considerable and prohibitive for a micro company.

### ***Personnel***

The fourth factor must be satisfied since the company's customers, at least initially, are English speaking. If the country does not have a sufficiently large technical pool of English speaking candidates, a large and delaying investment in training would need to be made. If its customers were primarily in, for example, Europe, the company would probably be better served by searching for providers in Eastern Europe.

### ***Infrastructure***

Factors five and seven relate to available facilities in the country. As was pointed out, items of hardware, software and other moveable capital items can be imported, the external network communications backbone is essential. A dedicated satellite communications network is a possibility for a mid to large company, but not for the micro or small company.

For the international outsourcing option, there needs to be present service providers. If the company is establishing a foreign office, having some previously established business connection in the country is a great advantage.

### ***Culture, Legal and Location***

If the management of the company had no international experience, factor six, the international support option should not be considered. The only exception would be if the company's management worked with a consultant in which they had great confidence. Otherwise, any internationalization plans should be delayed until enough experience can be gained or purchased.

The legal environment is addressed by factor eight. Ad-Station does have some proprietary technology that it wants to protect. Adequate protection needs to be provided in the country's legal system and in the company's processes.

The last factor, time zone, is a relatively minor issue, but can add to the attractiveness of a location. However, most locations in Asia would be grouped together in evaluating this factor. They are 10 to 14 hours out of phase with the east coast of the United States. Depending upon the type of support required this can be an advantage or disadvantage.

## **THE COMPANY'S APPROACH**

A number of countries were considered. As India is the current country of choice for much international outsourcing activity, it was given consideration. However, on the cost basis alone, India is not attractive. Recent information indicates that India may already be losing its edge as a leading international outsourcing destination (Bhatnagar, 2005). Based on the factors listed above the Ad-Station selected the Philippines as the place to outsource to and, later, establish an office.

The wage rates in the Philippines are low for the skill set required by Ad-Station, lower than India, for example. The bulk of the search costs are eliminated since the company has use of an established base. This also permitted establishing support much more quickly. The company's process is designed to protect against increased opportunity costs arising from this function. The plan to shift to a local office will allow Ad-Station to maintain closer control over the operations of the support function. An added benefit of contracting for services first, is that it permitted Ad-Station the opportunity to evaluate the skills of the personnel under operational conditions, before hiring. Moving this function to this foreign location is expected to reduce Ad-Station's costs by \$70,000 per year for the first two years. This is a considerable amount for a micro start-up.

The Philippines is 11 to 12 hours ahead of the East coast of the United States. This provides the opportunity to supply overnight support from a region during its daytime work period. Some of Ad-Station's products will require support on a twenty-four hour basis. The Philippine office, when it is fully functional, will be able to assume its support role when the United States office is ending its normal shift.

## **MODEL OF THE CUSTOMER FULFILLMENT PROCESS**

The company's management team was considering a major change from the way most small independent startup companies would provide their customer support and fulfillment processes. The proposed path was projected to reduce direct costs of operation considerably over time. However, there was still the risk of increased opportunity costs which might arise from a degradation of customer service. Management wanted some assurance that this would not occur. In addition, there would be costs associated with establishing the international operation. Management wanted to avoid these if the probability of success of the international approach appeared low.

In order to determine whether there would be any major detrimental impact to customer fulfillment, an industrial or system dynamics model (Forrester, 1961) was developed for a segment of the fulfillment process. The modeled portion of the process is that included in the dotted rectangle in Figure 2.

This model allowed management to study how the interactions within the process would impact performance in a relative sense. The critical issue was the relative performance of the system functioning entirely United States based or with a component operating in a foreign location. The process had only been effectuated under test conditions in an entirely United States location. Management had no experience regarding the level of performance that would be encountered in the foreign location. Management relied on its experience with personnel in the foreign location to gauge the level of effectiveness that might be realized from personnel in that location. However, it was still necessary to make assumptions regarding the level of the variables in the model. Since it was only the relative impact that was of interest at this point, the model could provide useful information regarding the advisability of sourcing some of the process functionality offshore.

A diagram of the industrial dynamics model is shown in Figure 3. The process was modeled as a system of accumulations (rectangles), flows (thick arrows between rectangles), and feedback loops (circles with arrows). The feedback loops permit the implementation of decision rules that impact the performance of the system.

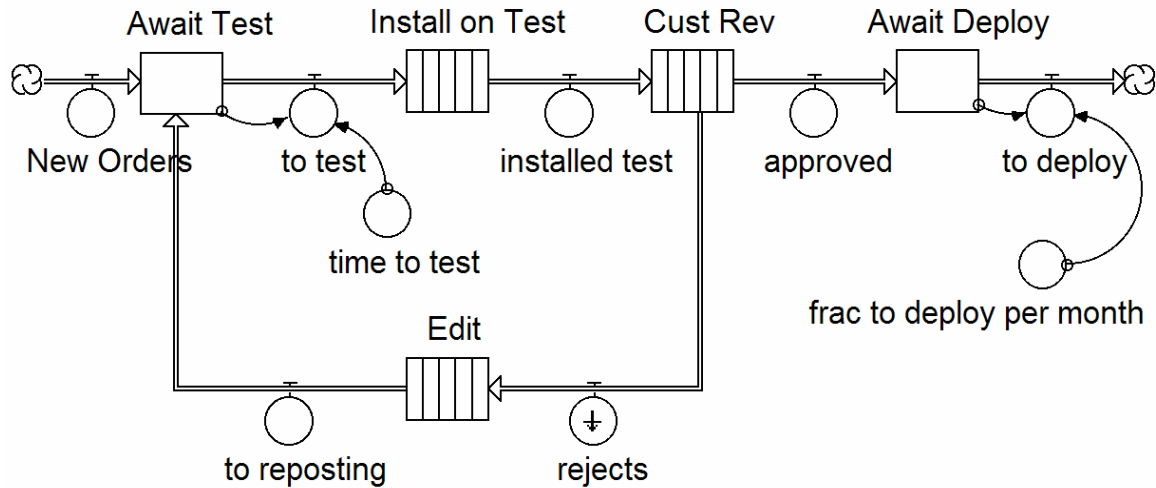

Figure 3: Industrial Dynamics Model of Segment of Customer Fulfillment Process

The key variable that was tested in the initial runs was the impact of the time to install an ad on the test site. An increase here was expected to delay the time to deploy an advertisement. Because of delays in communication it was felt that a 50% increase in the amount of time was reasonable. However, much larger variations were tested. Figure 4 shows the comparison of results after increasing the foreign location test time by a factor of three over the time required in the United States (US). The results show that the impacts even at this high level, 300% increase, is acceptable.

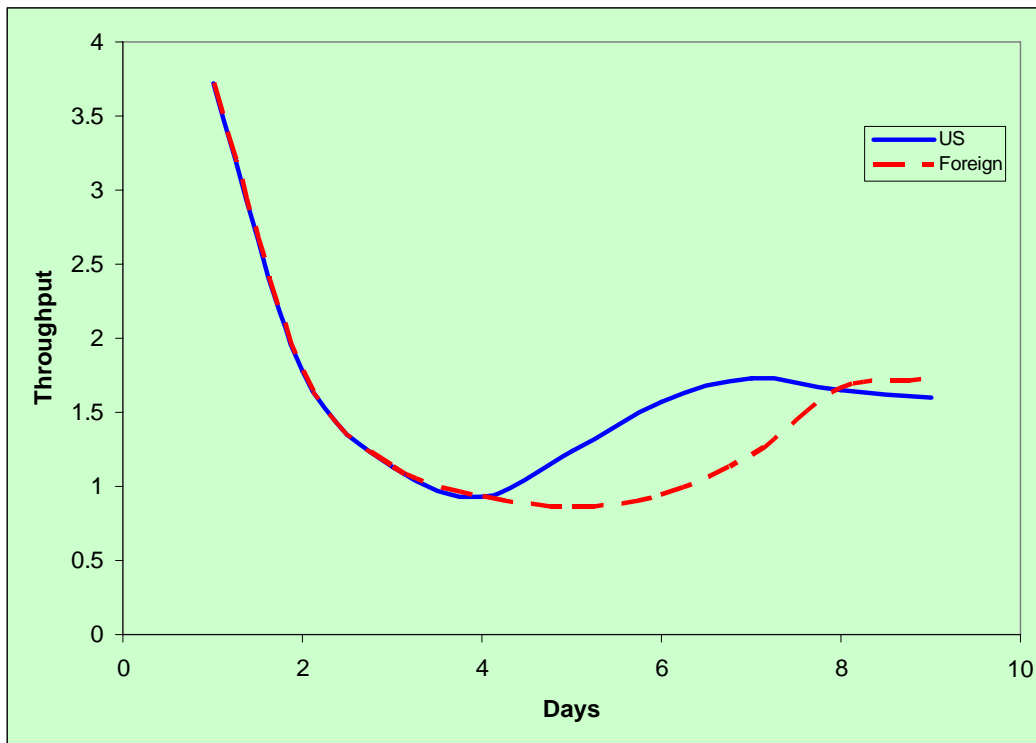

Figure 4: Model Sensitivity Results

Several other sets of initial and process conditions were used. The results were comparable for each set of conditions. Absolute levels were different, often significantly different when process conditions were changed, but the relative performance between an entirely United States located process and the mixed operation was approximately the same. There was a slight advantage to a United States only operation during process startup, as seen in Figure 4. The advantage disappears as process implementation advances.

The model provided additional insight into the dynamics of the process by revealing that interactions with the customer are expected to have a far larger impact on the processing time than are the other functions.

This is a preliminary model which will be refined and expanded to help improve the company's processes. Its use also points out that industrial process modeling can provide useful insights even for small company operations, and that this technology is now also within the ability and price range to be a viable tool for the micro-multinational company.

### SUMMARY

This report demonstrates that the information technology is available for even the smallest companies to participate in the cost savings that may be realized from outsourcing some functionality to a foreign location. It also demonstrates that the means to evaluate the comparative success of such a venture is within the means of these companies. The factors that the subject company, Ad-Station Systems, Inc., incorporated into its decision process are general, and can be used by any company attempting to implement an outsourcing process. The specific weights assigned will differ depending upon the specific circumstances of each company.

### REFERENCES

- Amiti, M. and Shang-Jin Wei (2005). Fear of Service Outsourcing: Is It Justified? *Economic Policy* 20, 307-347.
- Bhatnagar, P. (2005). Is India's Outsourcing Honeymoon Over? *CNN Money*, August 24, 2005. Retrieved April 15 from [http://money.cnn.com/2005/08/23/news/international/india\\_outsourcing/](http://money.cnn.com/2005/08/23/news/international/india_outsourcing/)
- Brainard, L. and Litan, R.E. (April 2004). "Offshoring" Service Jobs: Bane or Boon and What to Do? *Global Economics*, Brookings Institution, Policy Brief #132, 3
- Feenstra, R.C. and Hanson, G.H. (1999). The Impact of Outsourcing and High Technology Capital on Wages: Estimates for the United States, 1979-1990. *Quarterly Journal of Economics*. 114(3), 907-940
- Forrester, J.W. (1961). *Industrial Dynamics*. Productivity Press, Portland, OR.
- Gorg, H., Hanley, A. and Strobl, E. (December 2005). Productivity Effects of International Outsourcing: Evidence from Plant Level Data. Research Paper 2003/20, University of Nottingham
- Gumpert, D (2004). Growing Concerns, *Business Week Online*. Retrieved April 23, 2006 from [http://www.businessweek.com/smallbiz/content/jul2004/sb20040713\\_5522\\_sb035.htm?campaign\\_id=search](http://www.businessweek.com/smallbiz/content/jul2004/sb20040713_5522_sb035.htm?campaign_id=search)
- Hummels, D., Ishii, J. and Yi, K-M. (2001). The Nature and Growth of Vertical Specialization in World Trade. *Journal of International Economics* 54, 75-96
- Ogasawara, T (January 4, 2004). Interesting Offshore Outsourcing Survey Responses in Software Development Magazine. Retrieved April 12, 2006 from [http://www.oreillynet.com/mac/blog/2004/01/interesting\\_offshore\\_outsourci.html](http://www.oreillynet.com/mac/blog/2004/01/interesting_offshore_outsourci.html)
- Woolley, D.R. (2006). Web Conferencing Guide. Retrieved 2005-2006 from <http://www.thinkofit.com/webconf/>